

DC1

High Security *Anti-Bump* **Restricted Key System**

- » **Patented Anti-Bump feature**
- » **Design registered keyway**
- » **Multi level, multi broach system**

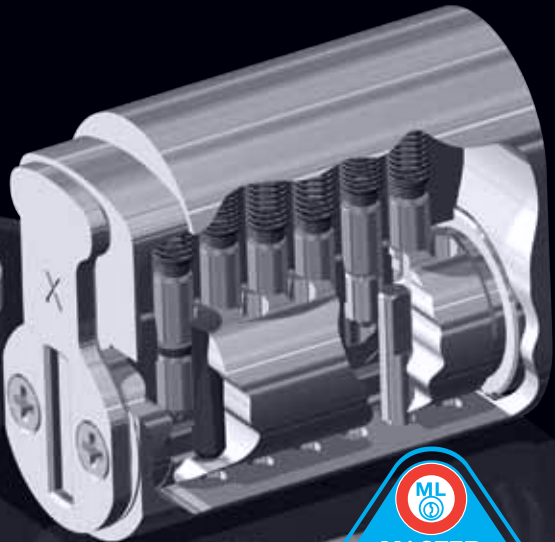

Your *Restricted* Key System



In order to effectively manage your staff & premises, your key system should offer you high levels of security, flexibility and quality. Many key systems achieve some of these aims but only DC1 can give you the entire package in one product range.

Lock bumping is now becoming more of a security issue in Australia. DC1 has the additional strength of a patented optional Anti-Bump design. Talk to your Master Locksmith Association Member if you are concerned about lock bumping.

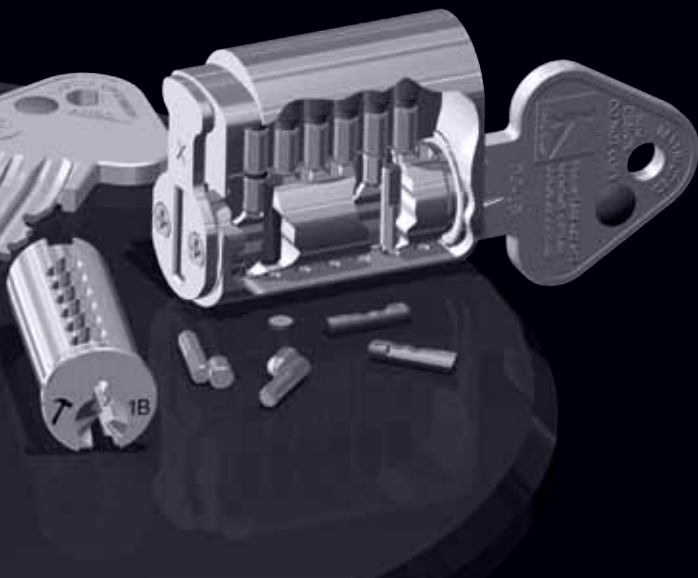

DC1

Why is *DC1* different?

Security

- **Master Locksmiths Association of Australasia**

The Master Locksmiths Association of Australasia is the peak industry body for locksmiths. This MLAA product ensures you're choosing a system that meets the highest security standards.

- **Unique patented Anti-Bump system**

DC1's unique Anti-Bump pin design gives you peace of mind. The system is fully optional and can be added by your locksmith.

- **Highly pick resistant key broach**

For added security the complexity of design in the DC1 key broach makes it extremely difficult to pick.

- **Design Registered Keyway**

Gives you the peace of mind that your key cannot be copied by unauthorised users. The key design is protected by Australian and New Zealand law.



Flexibility

- **Coloured plastic key inserts available**

A great visual aid to allow you to easily manage your staff access & door control.

- **Complete range of cylinders**

The DC1 range includes cylinder housings to suit all major commercial & residential lock types. From mortice locks & leversets to deadlatches, DC1 has it covered.

- **Multi level, multi broach system**

Multiple key broaches and levels available allowing greater control of your key system.

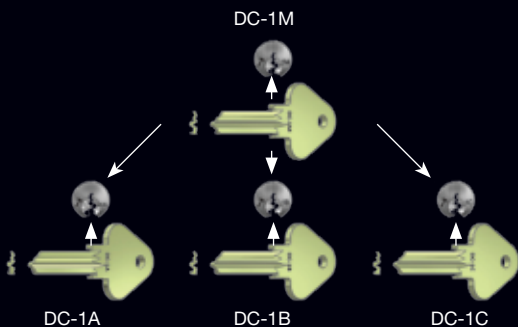

Quality

- **Manufactured to high precision standards**

All DC1 components have been designed in Australia to the highest standards. The DC1 range is manufactured by lock manufacturing experts with many years of experience.

Your local Master Locksmiths Member is: